SMAC

The ability to do work and verify its accuracy

SMAC
Actuators User Manual

SMAC | 5807 Van Allen Way | Carlsbad | California | 92008 | USA
SMAC Europe Limited | Tel 01403 276488 | Fax 01403 256266

P. Marks 05.05
Revision 1.8

Contents

Description	Page
Actuator Working Principals	3
Installation Guide	5
Notes for operation	7
Precautions	8
Grounding and Shielding Advice	9
Using SMAC Amplifiers	10
Appendix	13

Part 2

Configuring your computer	22
Setup instructions	23
Controller Parameters	24
PID values	25
Registers	26
Programmers Notes	27
Sample program	32
Input / Output Channels	38

Actuator Working Principles

Actuator Components

Moving Coil	Powers linear motion
Linear guide	Guides linear motion
Bumpers	Adjustable end stops
Limit Switch	End of stroke sensors
Thermistor	Detects overheating
Piston	Carries coil, rod and DC motor. Mounted to linear bearing
Bearing/Bushing	Guides rod through body
Optical encoder	Measures distance travelled by piston
Glass Scale	Optical encoder scale
Encoder detector head	Reads the optical scale
Index line	Locates a fixed position on the scale
DC motor	Rotates the rod
Gearbox	Connects motor to rod
Rotary encoder	Measures angular distance traveled
Rotary index	Locates a fixed position on the scale
Rotary Coarse Index	Proximity switch to detect rotary home

Method of operation

Linear Motion

The piston rides on a linear bearing carriage, which slides on the linear guide rail. A copper coil is mounted on the piston. This coil rides inside a magnet assembly. When current flows in the coil, a reaction force is produced causing the piston to slide along the guide. Bumpers are set at each end of the travel to cushion any impact force that may occur. Flags carried by the piston activate limit switches before the end of travel is reached. Either the glass scale of the optical encoder or the reader head is carried by the piston. As the piston moves, the detector head reads the distance travelled. An index line on the glass scale is used as a home location. The actuator rod exits the body through the bearing to maintain alignment. A thermistor is present in the actuator to signal an overheating condition.

Rotary Motion (LAR series only)

An assembly comprising a rotary DC motor, magnetic encoder and gearbox is carried by the piston to rotate the rod. The rod is mounted to the piston in a rotary bearing. The rod and gearbox shaft are connected using a flexible coupling. To locate a home position for the rotary axis, the actuator rod carries a flag. This flag is sensed by a reflective proximity switch and is identified as the coarse index.

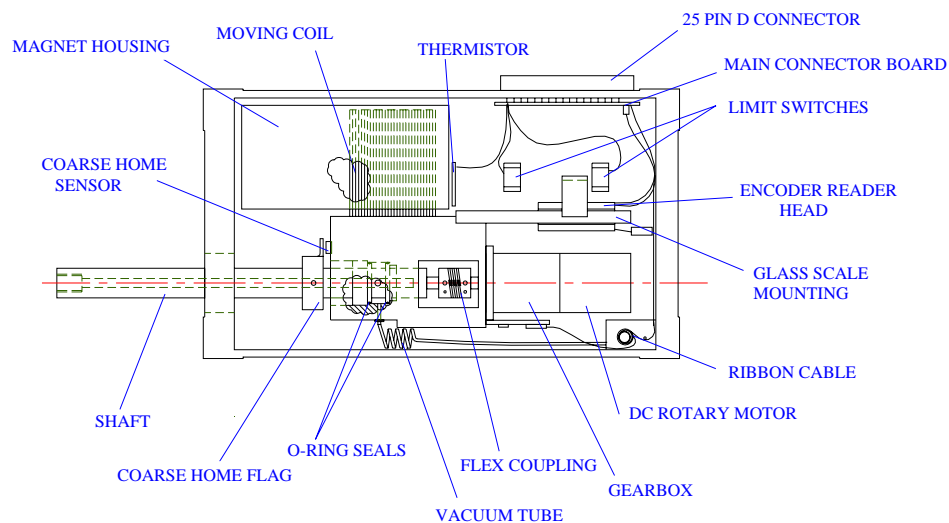

Fig 1. Actuator Components (LAR30-15 shown)

SMAC equipment required to run a system

Linear Actuator only:

LAL series actuator
LAC – 1 Controller
LAH-LO(D)-03 Cable

Linear / Rotary Actuator:

LAR series actuator
LAC – 25 controller
LAH-RT(D)-03 cable

Other equipment required

RS232 cable and connector (appendix page 1)
Laptop PC or text editor to construct program (see setup instructions)
26 pin I/O connector for Input/ Output channels
Either 24 Volt D.C., 4 Amp Power supply (30, 37, 50 series)
Or 48 Volt D.C., 4 Amp Power supply (90, 300 series)

Installation Guide

Note: Customers manufacturing their own cables please refer to page 7 of this manual for advice on shielding and grounding.

The actuator must be mounted using the tapped mounting holes provided, and users must ensure that mounting surfaces are flat in order to prevent any distorting of the body when the unit is tightened down (see Figure 2).

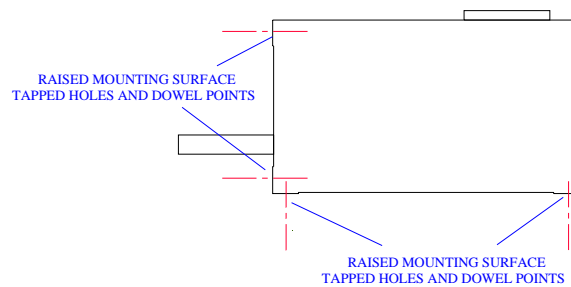

Fig 2. Actuator Mounting Points

If attaching anything to the rod of the actuator using the threaded part of the rod, use the spanner flats provided to prevent the rod rotating. Do this with the rotary motor powered off as damage may be caused to the gearbox if it is overloaded (turned with the power on).

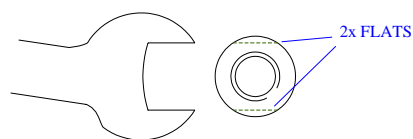

Fig 3. Use spanner flats

The actuator housing and controller housing should both be connected to the same grounding point (Earth). This is usually the case when the units are screwed directly onto a machine chassis. If they are not screw mounted then a ground wire should be attached to each of the units and this should be connected to Earth. As these are anodized it may be necessary to attach the wire to one of the steel screws, or to put a small scratch on the housing to ensure a good connection. It is possible to connect the components to different ground points, but they

must be at the same voltage level. Failure to do this may cause a current to flow from one point to another and this may result in noise.

AC power usually generates the operating voltage (e.g. 24v) which is DC and is isolated (not connected to earth). The power supply has two terminals, 24v and 0v. This operating voltage is used to generate a 5v DC reference voltage. This also has two terminals 5v and 0v. These two 0v terminals are connected together but still isolated from earth. The system will work if these are not connected to earth but problems may arise when the RS232 is connected. The RS232 ground is connected to the 0v connection in the controller. When it is connected to a PC, the ground wire is then connected to earth. If this causes problems the following actions will help:

- Plug the power supply to the same AC outlet as the PC
- Connect the 0v terminal to Earth

Note - the 0 volt terminal of the controller is connected to the metal shield of the connector. As this is screwed into the controller housing, the 0 volt is then effectively connected to Earth when the controller housing is earthed. Therefore it is not usual to see a problem when connecting a PC to the controller.

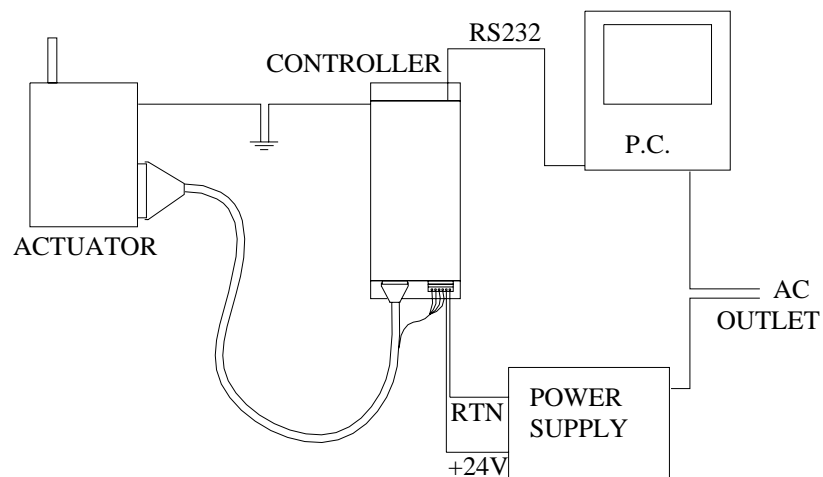

Fig 3. Grounding layout

Notes for installation and operation

If the actuator is in a vertical plane without a return spring fitted, the rod will drop if power to the unit is lost. Users must be aware of this as it may damage the end effector being used and also will affect Emergency Stop procedures and re-set sequences.

All units must be operated with a 40% maximum duty cycle, this can be calculated as follows:

% of max force applied x % of cycle time it is applied = % duty cycle

e.g.

100% force x 40% of cycle time = 40 % duty

60% force x 50% of cycle time = 30 % duty

40% force x 100% of cycle time = 40 % duty

Recommendations from SMAC are that this duty cycle must not be exceeded over a one second time period.

NOTE: Failure to observe this duty cycle recommendation will usually result in the actuator sustaining damage through overloading. Overloading will overheat the coil and may cause it to deform and touch on the magnet housing.

If the actuator is in vertical plane with no spring return, it will use a certain amount of power just to hold its position. If the payload is excessive, this alone could be enough to exceed the duty cycle.

Laws of physics state that : Force = Mass x Acceleration

The actuator has a low moving mass, therefore with constant force applied and no load, a large acceleration will result. This will drive the rod into the endstop on the actuator and may cause damage if it is repeatedly done.

The actuator is a precision piece of equipment in terms of both force and position. Alignment of the linear axis components must be maintained to ensure smooth running of the rod. To ensure it remains functioning in the correct manner it is advisable to follow the guidelines.

Precautions:

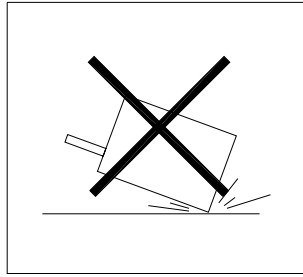

Handle the actuator carefully, do not drop it or subject it to excessive shock loading

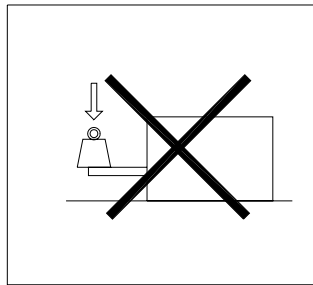

Do not apply excessive side loads to the rod, this can lead to increased friction and wear on the internal components

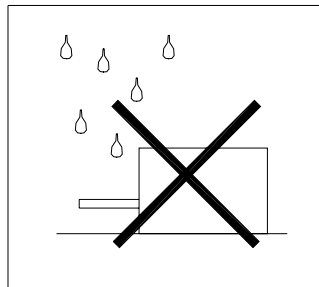

Avoid putting the actuator in hazardous environments such as wet, dusty, very hot (>50° C), very cold (<0° C). Consult SMAC if the actuator is required to work in these environments.

Other points to note:

- Use the optical index to home the actuator on a regular basis, this is especially important when the actuator is being moved around on another axis, or subject to vibration.
- Avoid powering the rod into the endstops (this is also related to duty cycle)
- Get familiar with the actuator by first using it on a horizontal surface with no load and limited force

Shielding and grounding advice (for customers manufacturing their own cable)

Note: Using non-SMAC cables will invalidate the warranty unless the cable is checked by an SMAC engineer.

Shielding

Noise from wires carrying the coil power needs to be prevented from leaking out – these wires need to be twisted pairs held inside a shielded cable.

Encoder signals need to be shielded from noise – these should also be twisted pairs held inside a separate shielded cable.

The shield should cover as much of the wire it is shielding as possible. This means that the encoder signals shield should start as close to the encoder detector circuit as possible and terminate as close to the controller connector as possible. The shield for the coil power lines should follow the same pattern. The shield must therefore cover the whole distance between actuator and controller.

For the shields to work they must be connected to a noise free connection, the closer this is to the input the better. This means that for the encoder signal cable the shield should be connected to the 0v terminal of the operating voltage at the controller connector. The power cable shield should be connected to the actuator ground (Earth).

Drawings are available on request from SMAC.

Use of SMAC Amplifiers

The SMAC amplifier is intended for use in conjunction with generic servo controllers. The amplifier runs from an 11-50 Volt DC power supply, dependent on the actuator being used. In order to achieve maximum power from the largest units (LAL90, LAL300), a 48V, 5Amp DC supply is required, otherwise 24V, 5 Amp DC is used.

The amplifier takes a ± 10 V signal from the servo controller, which is used to generate a ± 6 Amp peak output* to the actuator. This input is connected to pins 13 (± 10 V), and pin 25 (0V reference). Encoder pulses pass back through the amplifier directly to the controller which must be able to interpret these signals. The controller should then adjust its ± 10 V output to maintain the required trajectory. The encoder is powered from the 5v input from the servo card or PC. This signal should be 5.1V \pm 0.1V and free of electrical noise.

The encoder signals are square wave, 3 channel TTL level quadrature outputs. Most actuators use a differential signal though older units will be single ended. Consult SMAC to confirm specification of your unit:

Single ended signals will consist of encoder Channels A⁺, B⁺, I⁺.

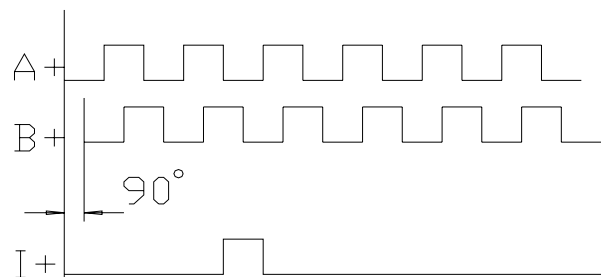

Differential signals will have additional channels A⁻, B⁻, I⁻.

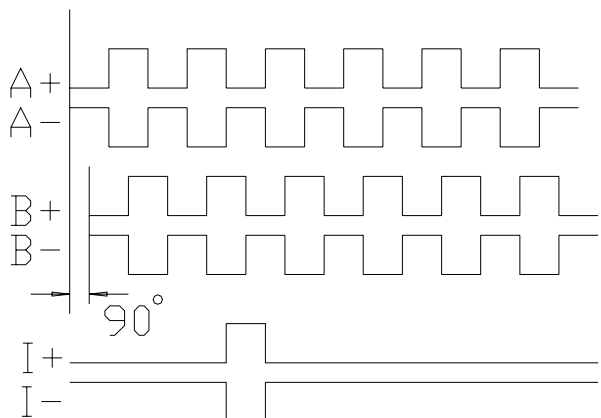

* Note: Verify maximum current requirement of the actuator being used, usually 2 or 3 Amp.

There are two dedicated input and output signals.

The overtemperature output from the amplifier signals an overheat condition inside the actuator. These pins are wired straight through the amplifier from the electronic thermistor circuit inside the actuator and will switch a 5v signal which should be applied across pins 6 (+5v) and 7 (0v).

There is also a fault signal which becomes active if the amplifier is overheated. This channel is capable of switching between 5 and 30 V at 10 mA across the fault pin (11) and fault return (23).

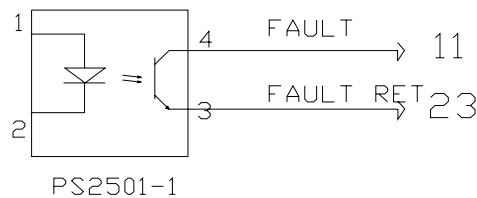

Amplifier fault Circuit

An inhibit input to the Amplifier from the controller will shut off power to the actuator. The output from the inhibit signal is 9 V. Placing a ground between pins 12 (inhibit) and 24 (inhibit return) will cause the amplifier to shutdown (output goes to zero):

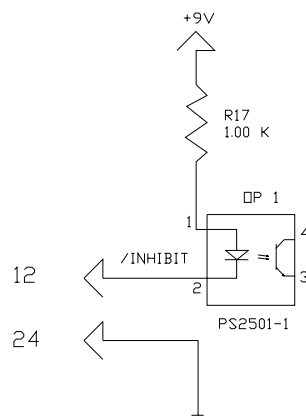

Inhibit Circuit Diagram

Limit switch signals are present on pins 8 (extend) and pin 9 (retract). The return pin for both of these is pin 10. They are normally open circuit. When the limit switch is activated, the resistance across these pins will go to 7kΩ. This can be used to switch a 24V signal. A pull-up resistor may be necessary across the supply to these pins, measuring across the resistor will show the voltage going to zero when the limit is active.

The case of the amplifier should be connected to a ground point to reduce the effect of any electrical noise which may be present in the system.

Diagrams of pin assignments for wiring the amplifier can be found in Appendix 1.

Pin Number	Description of connections
1,2	1=+5v, 2=+5v rtn -- 5v input from controller, often 5v from PC is used. 5.1v +/- 0.1v
3,4,5 14,15,16	3,4,5 = A,B,I encoder signals, 14,15,16 = A ⁻ ,B ⁻ ,I ⁻ signals. Encoder signals from actuator pass through amplifier to the controller. Max operating current = 140mA.
6,7	6 = overtemp, 7=overtemp rtn. A 5v 10mA current limited signal can be switched across pin 6 (+5v) and pin 7 (0v).
8,9,10	8=limit+,9=limit-,10=limit rtn. Pull-up resistor required 5 kΩ. Applying a voltage and measuring across the resistor will show 0v when limit is active.
11,23	11=fault, 23=fault rtn. Can switch up to 30V 10mA signal when active.
12,24	12=inhibit, 24=inhibit rtn. Connecting inhibit (pin 12) to ground (pin24) will inhibit the output from the amplifier.
13,25	13= +/- 10v command signal, 25=0v reference for signal.
Other pins	Not used

If a 24V fail safe limit signal is required (Active limit = 0V), the following circuit can be used

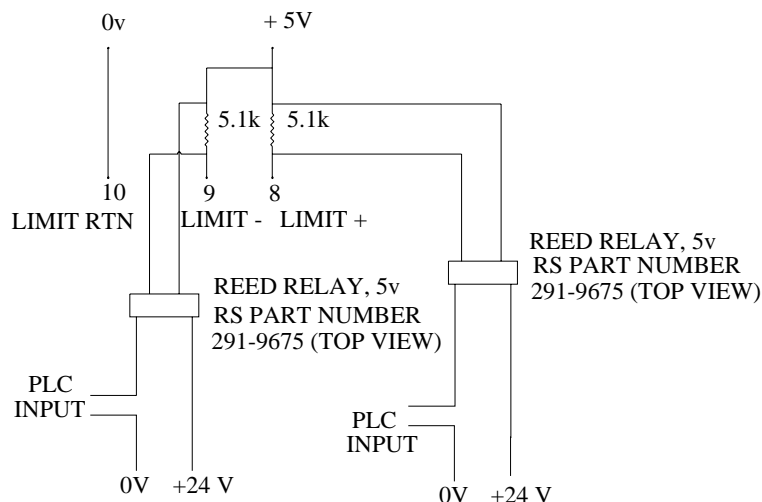

Limit Switch signal to 24V

Appendix 1

Diagrams

LAA-5 AMPLIFIER - ACTUATOR CONNECTOR, FEMALE (OUTPUT TO ACTUATOR)

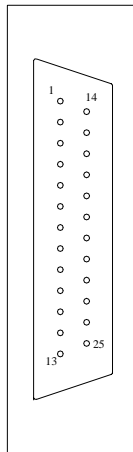

PIN NO.	DESCRIPTION	
1	+ 5 VOLT	} 5 VOLTS TO ACTUATOR FROM CONTROLLER
2	5 VOLT RETURN	
3	PHASE A+	} PASS THROUGH AMPLIFIER
4	PHASE B+	
5	INDEX +	} PASS THROUGH FROM ACTUATOR
6	OVER TEMPERATURE	
7	OVER TEMPERATURE RETURN	} PASS THROUGH FROM ACTUATOR
8	LIMIT +	
9	LIMIT - RETRACT	} PASS THROUGH FROM ACTUATOR
10	LIMIT RETURN	
11	FAULT	} OUTPUT SHUTDOWN BIT OPEN COLLECTOR OPTO
12	INHIBIT	
13	MOTOR +	} POWER TO ACTUATOR COIL
14	PHASE A-	
15	PHASE B-	} PASS THROUGH FROM ACTUATOR
16	INDEX -	
17	NOT USED	
18	NOT USED	
19	NOT USED	
20	NOT USED	
21	NOT USED	
22	ROTARY COARSE HOME	
23	FAULT RETURN	
24	INHIBIT RETURN	
25	POWER RETURN FORM COIL	

TOLERANCES
(UNLESS STATED)
X. = +/- 0.5
X.X = +/- 0.1
X.XX = +/- 0.05

SMAC EUROPE LIMITED

UNIT 6, CITY BUSINESS CENTRE, BRIGHTON ROAD, HORSHAM, RH13 5BA
TEL. -- 44 1403 276488 FAX: -- 44 1403 256266

MATERIAL	PART NAME	DRAWN BY
DATE	24/02/99	P MARKS
SCALE	TITLE	
	ACTUATOR CONNECTOR	

LAA-5 AMPLIFIER - CONTROLLER CONNECTOR, MALE (INPUT FROM CONTROLLER)

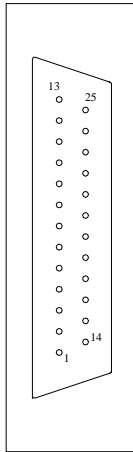

PIN NO.	DESCRIPTION	
1	+ 5 VOLT	5 VOLTS FROM CONTROLLER
2	5 VOLT RETURN	
3	PHASE A+	PASS THROUGH AMPLIFIER
4	PHASE B+	
5	INDEX +	PASS THROUGH FROM ACTUATOR
6	OVER TEMPERATURE	
7	OVER TEMPERATURE RETURN	PASS THROUGH FROM ACTUATOR
8	LIMIT +	
9	LIMIT - RETRACT	PASS THROUGH FROM ACTUATOR
10	LIMIT RETURN	
11 *	FAULT	OUTPUT SHUTDOWN BIT OPEN COLLECTOR OPTO
12 *	INHIBIT	AMP ENABLE BIT, LED OF OPTO
13	V. SERVO COMMAND	+/- 10 VOLT COMMAND FROM CONTROLLER
14	PHASE A-	
15	PHASE B-	PASS THROUGH FROM ACTUATOR
16	INDEX -	
17	NOT USED	
18	NOT USED	
19	NOT USED	
20	NOT USED	
21	NOT USED	
22	ROTARY COARSE HOME	
23	FAULT RETURN	
24	INHIBIT RETURN	
25	V RETURN, SERVO COMMAND	

* PIN 11 = OPTO ISOLATED OUTPUT, MAX CURRENT IC = 50mA

* PIN 12 = OPTO ISOLATED INPUT, MAX CURRENT IP = 80mA

TOLERANCES (UNLESS STATED) X. = +/- 0.5 X.X = +/- 0.1 X.XX = +/- 0.05		SMAC EUROPE LIMITED SUITE GA, BISHOPS WEALD HOUSE, ALBION WAY, HORSHAM RH12 1 AH TEL. -- 44 1403 276488 FAX: -- 44 1403 256266	
MATERIAL	PART NAME	DRAWN BY P MARKS	
DATE	24/02/99	TITLE	
SCALE		CONTROLLER CONNECTOR	

ENTRY FOR
 "DATA PATCH CORD GREY"
 6 WAY RJ11 PLUGS
 3 METRES
 (RS PART 446-664)

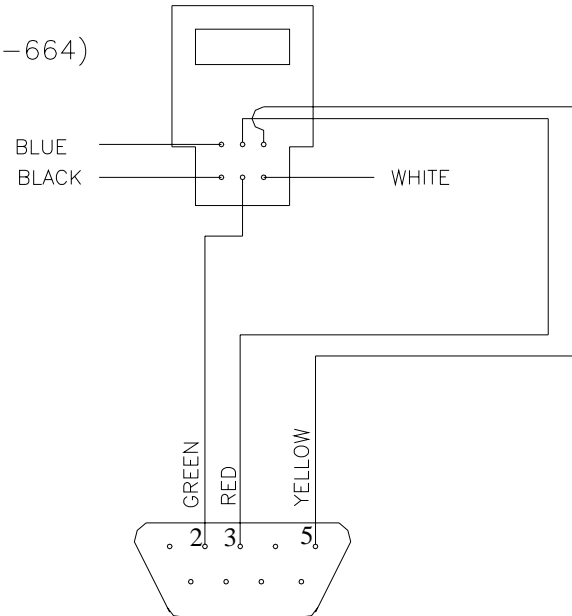

LAC-1 & LAC-25 RS232 CABLE

USING KIT RJ11 TO 9 WAY
 D SOCKET ADAPTOR
 (RS PART 452-6708)

TOLERANCES
 (UNLESS STATED)
 X. = +/- 0.5
 X.X = +/- 0.1
 X.XX = +/- 0.05

SMAC EUROPE LIMITED
 SUITE GA, BISHOPS WEALD HOUSE, ALBION WAY, HORSHAM, RH12 1AH
 TEL. -- 44 1403 276488 FAX: -- 44 1403 256266

MATERIAL	PART NAME	DRAWN BY
DATE	TITLE	P MARKS
SCALE	RS 232 CONNECTION	

25-WAY ACTUATOR CONNECTOR

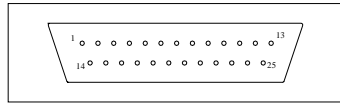

PIN NO.	DESCRIPTION
1	+5 VOLT
2	5 VOLT RTN
3	NC
4	ENCODER A-
5	OVERTEMP
6	OVERTEMP / LIMIT RTN
7	COIL +
8	COIL +
9	ENCODER B-
10	NC
11	LIMIT +
12	LIMIT -
13	NC
14	ENCODER A+
15	NC
16	ENCODER B+
17	NC
18	ENCODER I+
19	COIL -
20	COIL -
21	NC
22	NC
23	ENCODER I-
24	NC
25	NC

26-WAY ACTUATOR CONNECTOR

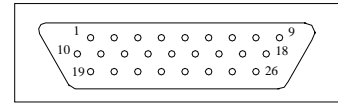

PIN NO.	DESCRIPTION
1	ENCODER A+
2	ENCODER B+
3	ENCODER I+
4	NC
5	NC
6	OVERTEMP / LIMIT RTN
7	NC
8	NC
9	NC
10	ENCODER A-
11	ENCODER B-
12	ENCODER I-
13	NC
14	LIMIT +
15	LIMIT -
16	NC
17	NC
18	NC
19	+5 VOLT
20	5 VOLT RTN
21	COIL +
22	COIL +
23	COIL -
24	COIL -
25	NC
26	NC

TOLERANCES (UNLESS STATED)

X. = +/- 0.5
 X.X = +/- 0.1
 X.XX = +/- 0.05

ALL DIMENSIONS IN mm

SCALE

SMAC EUROPE LIMITED

SUITE GA, BISHOPS WEALD HOUSE, ALBION WAY, HORSHAM, RH12 1AH
 TEL: -- 44 1403 276488 FAX: -- 44 1403 256266

MATERIAL	PART NAME	DRAWN BY
DATE	TITLE	

Actuators User Manual

Part 2 - Programming Instructions

SMAC | 5807 Van Allen Way | Carlsbad | California | 92008 | USA
SMAC Europe Limited | Tel 01403 276488 | Fax 01403 256266

P. Marks 08/02
Revision 1.6

Configuring your Computer

To communicate with SMAC controllers, any text editor can be used. Normally a laptop running Windows 3.1 or Windows 95/NT is used.

Windows 3.1

1. In program manager, select accessories window, double click on 'Terminal'
2. If previously configured, open SMAC.trm, jump to step 8.
3. Otherwise select settings from the pull down menu, click on communications.
4. Setup as follows: Baud Rate - 9600
Data Bits - 8
Stop Bits - 1
Parity - None
Flow control - Xon/Xoff
Connector - COM1 Click 'OK'
5. Select settings from the pull down menu, click on Text Transfers.
6. Setup as follows: Flow control - Line at a time
Delay between lines - 2/10 sec
7. Save as SMAC.trm.
8. With power to the controller, pressing the 'esc' key should give a greater than sign (>) indicating the unit is communicating properly.

Windows '95 or NT

1. Select programs, accessories then Hyperterminal. Double click on Hypertrm icon. If SMAC.trm has previously been setup, click this icon and jump to step 8.
2. Enter name for program (e.g. SMAC.trm) and choose an icon, click 'OK'
3. Phone number window will appear. In 'connect using' window, choose Direct to COM1, click 'OK'.
4. COM1 properties will appear – set as follows:
Bits per second - 9600
Data Bits - 8
Parity - None
Stop Bits - 1
Flow Control - Xon/Xoff Click 'OK'
5. Select file from pull down menu, select properties, choose settings in properties window.
6. Click on ASCII setup, set line delay to 250ms, click on 'wrap lines that exceed terminal width.'. Click 'OK'.
7. Select file from pull down menu and save.
8. With RS232 connected and power to the SMAC unit, pressing the 'esc' key should display a greater than sign (>).

Set-up instructions

Equipment needed to program and run an actuator is as follows:

- An LAC-1 or LAC-25 controller
- SMAC cable for connection between controller and actuator
- SMAC actuator
- 24v or 48v DC power supply.
- Personal Computer running windows or other text editor.
- RS232 cable for connection between PC and controller.

The SMAC cable consist of a D-sub connector (usually 25 pin) at the actuator end and either a 15 pin (LAC-1) or 26 pin (LAC-25) D-sub connector at the controller end. There is also a green plastic 'Phoenix' power connector – **ensure this is connected in the correct orientation**. The RS232 cable consists of a 9 pin D-sub connector at one end and a 6 pin telephone type connector at the other.

To start the system

1. Connect J1 (26 or 15 pin) and green power connector to the controller.
2. Connect the 24v supply to the controller. Refer to the controller manual for the pin assignments.
3. Connect the RS232 between the computer and the controller. Refer to appendix for wiring diagram for this cable.
4. Select appropriate communication on PC. (Terminal, Hyperterminal)
5. Check all connections, when satisfied all is OK, turn on the power.
6. Press the 'esc' key, the prompt '>' sign should appear. Type **MF** to ensure the motor is off. If using an LAC-25, type **0MF**. (Note – typing 0MF on an LAC-1 controller will cause the controller to hang up. Re-power if this occurs).
7. Connect the 25 pin to the actuator.
8. Select Transfer menu and Send Text File, select program to send.
9. Type TM-2 (Tell Macros) to list program.
10. Type MS0 (Macro Sequence) to run the program.
11. Press the 'esc' key to stop the program, MF may need to be typed to turn the motor off if the program is stopped in mid sequence.

Setting the Controller Parameters

A **PID** control algorithm is used to ensure optimum response behaviour of the actuator to its input commands – reducing errors in velocity, acceleration and position.

P = Proportional Gain – This term determines the overall response of a system to position errors, providing an output signal proportional to the error at any time. A low Proportional gain provides a system which is very stable (doesn't oscillate), has low stiffness and possibly large position errors under load. A high proportional gain provides high stiffness and small positional errors under load, but may be unstable.

I = Integral Gain – This term helps the system eliminate positional errors caused by friction or loading by increasing the output to the actuator until the error reduces to zero. The error is added or integrated over time and eventually the controller generates a sufficient output to reduce it. A low Integral Gain may allow positional errors at rest, which depend on the static or frictional loads. Increasing the Integral gain will reduce these errors but if it is too high, the system may 'hunt' or oscillate at low frequency about the desired position.

D = Derivative Gain – This term provides damping and stability to the system by preventing overshoot. The controller analyses the change in error over time, in effect predicting what the error will be at the next time interval and adjusting the output accordingly. A low value of derivative gain allows a fast response to positional errors but may also allow the system to overshoot the desired condition. Large values of derivative gain will cause a slower response but may allow a higher proportional gain to be used without the system oscillating.

The SMAC controller allows the Proportional (SG command), Integral (SI command) and Derivative (SD command) values to be programmed. It is also possible to program associated values to enhance performance – Derivative Gain Sample Frequency (FR), Sample Rate of Integral Gain (RI), Integral Limit (IL).

The values tabulated overleaf should be used to setup the system initially. These may have to be adjusted to suit differing loading conditions, actuator orientations etc.

PID values for SMAC Actuators

Note: These are starting values only, they may need to be adjusted for different load values or actuator orientations. Values should work with both LAC-25 and LAC-1

For 0.5 μ and 0.1 μ , reduce all values by a factor of 5 (e.g. SG25 becomes SG5)

Linear Encoder	Actuator	Proportional (SG)	Integral (SI)	Derivative (SD)	Integral Limit (IL)
1 μ	LA*20	50	80	600	5000
5 μ	LA*20	100	200	1200	5000
1 μ	LAL30 / LAR30	50	100	600	5000
5 μ	LAL30 / LAR30	100	200	1200	5000
1 μ	LAL37 / LAR37	50	100	600	5000
5 μ	LAL37 / LAR37	100	200	1200	5000
1 μ	LAL55 / LAR55	50	150	600	5000
5 μ	LAL55 / LAR55	100	300	1600	5000
1 μ	LAL90 / LAR90	50	100	600	5000
5 μ	LAL90 / LAR90	100	200	1200	5000
1 μ	LAL90-50	50	100	600	5000
5 μ	LAL90-50	100	200	1200	5000
1 μ	Grippers	40	100	500	5000
5 μ	LAL300	100	300	1500	2000
Rotary					
Standard	LAR 30/37/55	150	200	1500	5000
1Nm	LAR90	20	200	300	1500
Direct Drive	LAR20/34/55	50	300	250	3000

It will also be necessary to program the following values. These values are nominal and can be changed to suit the motion profile as required during the program.

Command	Mnemonic	Value
Derivative Sampling Frequency	FR	1
Integration Limit	IL	5000
Phase	PH	0
Sampling rate of integral	RI	1
Set Acceleration	SA	1000
Set Velocity	SV	30000
Set torque	SQ	32767
Set Servo speed	SS	2
Set following error	SE	16383

These values can be displayed at any time by typing the **TK** (tell constants) command. Note that changing the **SS** command will alter the **SV** and **SA** values produced, as these are dependent on the clock speed.

Registers

Part of the non-volatile memory (NVRAM) of the controller is used to create a 256 by 32 bit register space. This means that variables can be stored, updated and retrieved during execution of a program. It is possible to store 32 bit numbers in any of the 255 registers. Register 0 is referred to as the accumulator, this is regarded as a temporary store for variables. The code required to store a number is as follows:

AL10000,AR220 Accumulator Load value 10000, Accumulator to Register 220

This will store a value of 10000 to register number 220. Typing the command **TR220** (Tell Register 220) will display 10000 (the contents of register 220) on the screen.

The command **MA@220,GO** would now be the same as typing **MA10000,GO**, the @ symbol shows that a register value is to be used.

Registers could, for example, be used to set up a counter to record the number of cycles carried out by the actuator. We would increase the value in a register by one each time a cycle is completed.

RA50,AA1,AR50 Register to Accumulator 50, Accumulator Add 1, Accumulator to Register 50. If we execute these commands each time we complete a cycle, the value in register 50 will be increased by one each time.

Preset Variables

There are areas in memory allocated to preset internal variables. It is possible to access these values at any time during execution of a program. This is important during such routines as a soft land (measure) routine, homing routine and for safety or damage checks during the cycle. We can access such variables as position error, position, input values.

For example to access the current position of axis 1, type **RL494** (Read Long word at address 494 to accumulator), this will transfer the current real position into the accumulator. The command **TR0**, (Tell Register 0 – i.e. the accumulator) will display this value on the screen.

There is a comprehensive explanation of all these functions, along with a list of preset variables on pages 44-51 of the LAC-25 manual, or pages 41-48 of the LAC-1 manual.

Programmers Notes

The controllers supplied by SMAC use a programming language similar in structure to assembler code. The code is held in non-volatile RAM in the controller. The language consists of two letter commands followed by a number, e.g. MN = Motor On, PM = Position mode. Programs are constructed using lines of code known as Macros, these are numbered and the program can be commanded to execute different macros, call subroutines and jump to different points dependant on conditions.

An example of macros might be:

**MD10,QM,MN,SQ10000,MJ20
MD20,WA1000,MF**

MD = Macro Definition	QM = Force mode
MN = Motor On	SQ = Set Force
MJ = Macro Jump	WA = Wait
MF = Motor off	

Notes: Macros are started by typing MS (macro sequence) followed by the number of the first macro to be executed

On power up of the unit the program will execute Macro 0 automatically.

Macros will continue to execute if they are in numerical order, otherwise an MJ command is required.

Default values are usually 0, check controller manual for full list of defaults.

LAC-25 controllers need to have an axis address (e.g. 1MN = Axis 1 Motor On, 2MN = Axis 2 Motor On, 0MF = Axis 1 and Axis 2 Motor Off)

(Note that with an LAC-1 controller these axis labels are not needed and will cause a fault. A re-power of the unit is necessary in this case)

Getting Started

SMAC systems consist of a controller, cable and actuator. The controller generates movement of the actuator as commanded by the software. A current is output to the coil of the actuator, this provides the driving force for the system. Position of the actuator piston is continually fed back by the linear encoder, this is monitored by the controller.

When the actuator is commanded to make a move through software, a trajectory is calculated for the move. The position of the actuator piston is monitored over time by the controller, and the force output is controlled to match the actual movement to the required movement. The difference between the actual position and required position is known as the position error. The controller will try to reduce the position error to zero at any time.

It is also possible to use the actuator without this feedback facility, the unit can run 'open-loop', ignoring the encoder feedback. The controller will generate a current through the coil which produces a constant force on the end of the rod. If there is no resistance to movement, the rod will accelerate due to the applied force.

Refer to the 'Actuator User Manual' for details of setting up system hardware.

Programming modes

There are three methods with which the actuator can be commanded to move - force mode, velocity mode and position mode. As follows:

Force Mode

Force mode is open loop, using no feedback from the encoder. Actual position is still monitored but has no effect on the output. The commands that are used are as follows:

MD100,MN,QM0,SQ32767

MN = motor on, QM = force mode, SQ = set force.

The range of values for the SQ command are from -32767 to $+32767$, corresponding to maximum force in positive (extending the rod) or negative (retracting) directions. This will generate an output from the PWM amplifier inside the controller. The output is almost linear, though towards the higher end of the scale there will be more energy lost through heat generation inside the coil, effectively reducing the force generated.

QM0 uses PWM to generate an output to the coil.

QM1 is a more accurate method to generate a force using one of the Analogue Input channels to monitor the actual current running through the coil. The commands for this method of programming would be as follows:

MD100,SC2000,MN,QM1,SQ500

SC = set current gain, MN = motor on, QM = force mode, SQ = set force.

Note that an SC value will need to be programmed to allow feedback to be monitored and outputs modified. The range of values for the SQ command are from -1023 to $+1023$, corresponding to a ± 5 Amp output generated from the controller. The maximum current that is used in the coil of the actuator is ± 3 Amp, therefore the maximum value would be SQ-600 to SQ600. Anything above SQ600 would have no effect on the current passing through the coil.

This allows us to calculate the resolution of the actuator output

Resolution = max force / 600. For a 100N unit: Resolution = $100\text{N} / 600 = 0.16\text{ N}$

This resolution is effective whether we work in QM0 or QM1.

Velocity Mode

This allows the rod to be moved with a given velocity, acceleration, force and direction.

The commands to use are as follows:

MD100,MN,VM,SA1000,SV100000,SQ10000,DI0,GO

MN = motor on, VM = velocity mode, SA = set acceleration, SV = set velocity, SQ = set force, DI = direction, GO = go

The SQ range is from 0 – 32767.

DI0 = direction which increases encoder count (extend), DI1 = direction which reduces encoder count (retract).

SA and SV are calculated as follows:

The controller calculates velocity in terms of encoder counts per update period:

For example: Velocity 10mm/s with 5 micron encoder, update = 200 μ s (standard LAC-1 / LAC-25)

$$10 \text{ mm / s} \times 200 \text{ (counts/mm)} = 2000 \text{ encoder counts / second}$$

$$2000 / 5000 \text{ (update periods / sec)} = 0.4 \text{ encoder counts per update period}$$

$$0.4 \times 65536 \text{ (internal constant)} = \text{SV26214} \quad \therefore \text{10mm/s} = \text{SV26214}$$

For example: Acceleration 100 mm/s², 5 micron encoder, update period = 200 μ s

$$100 \text{ mm/s}^2 \times 200 \text{ (counts/mm)} = 20000 \text{ counts/s}^2$$

$$20000 / 5000^2 \text{ (update periods / s}^2\text{)} = 0.0008 \text{ counts / update period}^2$$

$$0.0008 \times 65536 \text{ (constant)} = \text{SA52} \quad \therefore \text{100 mm/s}^2 = \text{SA52}$$

The most common application for using velocity mode is the ‘softland’ routine, where we use the actuator to land with a controlled force onto a component. The commands we use for this are as follows;

**MD100,MN,VM,SA1000,SV50000,SQ5000,DI0,GO,WA50
MD101,RW538,IG50,MG”LANDED”,MJ105,RP
MD105,TP,MF,EP**

MD100 – Starts the actuator moving in a positive direction with limited velocity and force.

MD101 – Word 538 is the address for the position error, if greater than 50 (IG50) the next two commands are executed i.e. the message is displayed and the program jumps to MD105. Otherwise these commands are ignored and the RP (repeat) command is executed, which repeats the macro.

MD105 – Tell Position will display the current position, Motor off, End Program.

Position Mode

Using position mode the actuator can be moved to various positions along the stroke. It is possible to set acceleration, velocity and force during the move.

It is possible to make absolute or relative moves or to store learned positions, which can be recalled later in the program.

The code used for position mode moves is as follows:

MD100,PM,MN,SA1000,SV100000,SQ20000,MA1000,GO

or

MR1000

or

MP20

PM = position mode, MN = motor on, SA = set acceleration, SV = set velocity, SQ = set force, MA = move absolute, (MR = move relative, MP = move position) GO = go

The numbers following the move command are the number of encoder counts to move.

Move Absolute will move the rod to an absolute position from the defined zero position.

Move Relative will move the rod a relative distance from the current position.

Move Position will move the rod to a previously defined position (requires a learned position LP command to store the position).

If moving to a number of positions in sequence, it will be necessary to pause between the moves, as follows:

MD100,PM,MN,SA1000,SV100000,SQ20000,MA100,GO,WS20,MA1000,GO,WS500,MA4000,GO,WS50,MG"FINISHED"

WS = wait stop, the value is the number of milliseconds to wait at that position. It is possible to program a WS0 command.

All SV, SA and SQ values will remain at their previously programmed values, it is only necessary to program them if they have to be changed from the previous value.

LOOK-UP TABLE FOR VELOCITY / ACCELERATION VALUES				
(USING LAC-1 / LAC-25, UPDATE RATE = 200 μS)				
5 MICRON ENCODER		1 MICRON ENCODER		
VELOCITY	SV VALUE		VELOCITY	SV VALUE
(mm/s)			(mm/s)	
1	2621		1	13107
5	13107		5	65536
10	26214		10	131072
15	39322		15	196608
20	52429		20	262144
50	131072		50	655360
100	262144		100	1310720
200	524288		200	2621440
500	1310720		500	6553600
1000	2621440		1000	13107200
2000	5242880		2000	26214400
ACCELERATION	SA VALUE		ACCELERATION	SA VALUE
(mm/s/s)			(mm/s/s)	
10	5		10	26
50	26		50	131
100	52		100	262
150	79		150	393
200	105		200	524
500	262		500	1311
1000	524		1000	2621
2000	1049		2000	5243
5000	2621		5000	13107
10000	5243		10000	26214
20000	10486		20000	52429

Sample Program – Testing the Encoder in a Program

Before the actuator can be moved, the encoder must be tested. If it is not tested and a fault is present, a large position error could build up. This would then cause a large output signal to be generated, resulting in rapid movement and crashing of the actuator into the endstops.

```
;    ENCODER TESTING ROUTINE
;
MF, RM
;
MD0, MF, PM, SQ32767, CF0, CF1, CF2, CF3, CF4, CF5, CF6, CF7, DH, AL1, AR3
MD1, AL254, LV27, EV27
MD2, FR1, SG@5, SI@6, SD@7, IL5000, SC2000, RI1
MD3, QM, MN, SQ-10000, WA5
MD4, RL494, IB-10, MF, MJ7, RA3, AA1, AR3, IG10, MF, MJ5, MJ4
MD5, AL1, AR3, WA200, SQ0, DH, MN, SQ10000, WA5
MD6, RL494, IG10, MF, MJ7, RA3, AA1, AR3, IG10, MF, MJ30, MJ6
MD7, MG"ENCODER CHECKED OK"
MD30, MG"ENCODER INOPERATIVE OR ACTUATOR CANNOT MOVE"
```

; ENCODER TESTING ROUTINE – Anything after the semi-colon is ignored by the controller, comments etc can be placed here.

MF, RM – Motor off, reset macros clears the memory.

MD0, MF, PM, SQ32767, CF0, CF1, CF2, CF3, CF4, CF5, CF6, CF7, DH, AL1, AR3 – Motor off, enter position mode reset force limit to maximum, turn off all channels, define home. Initialise a counter in register 3 and set it to 1 at the start.

MD1, AL254, LV27, EV27 – Load value 254 into vector 27 (overtemp). Enable vector 27.

MD2, FR1, SG@5, SI@6, SD@7, IL5000, SC2000, RI1 – This sets up the PID constants. The gain, integral and derivative are in registers 5, 6 and 7. These values will need to be loaded before the program is run.

MD3, QM, MN, SQ-10000, WA5 – Select torque mode, set force to one third maximum negative value, wait 5ms

MD4, RL494, IB-10, MF, MJ7, RA3, AA1, AR3, IG10, MF, MJ5, MJ4 – Read axis 1 current position, if below –10 counts (i.e. the rod has moved more than 10 counts in a negative

direction, as expected) turn motor off and jump to macro 7. Else read register 3 value, add 1 to it, store it back into register 3. If this is greater than 10, turn motor off and jump to MD5, else jump to the start of macro 4.

MD5,AL1,AR3,WA200,SQ0,DH,MN,SQ10000,WA5 – The program jumps here if it cannot retract the rod. Reset the counter, define home. Turn motor on, set force to 1/3 maximum positive, wait 5ms.

MD6,RL494,IG10,MF,MJ7,RA3,AA1,AR3,IG10,MF,MJ30,MJ6 – As for macro 4 but try to extend rod. If extended, turn motor off jump to macro 7, else increment the counter. If counter value is greater than 10, motor off jump to macro 30, else jump to macro 6.

MD7,MG“ENCODER CHECKED OK” – Message if all OK.

MD30,MG“ENCODER INOPERATIVE OR ACTUATOR CANNOT MOVE” – Fault message.

MD254,MG“OVERTEMP”,MF – Over-temperature message.

Sample Routines

Softland Routine

This is the routine which enables the actuator to land on a surface with a low force, for example to measure a component. This is done in velocity mode, monitoring the position error as the rod is moving with a controlled force. It is also possible to set a position window where the component should be located, if it is not located within a certain position, the rod will retract.

The code used is as follows:

```
MD100,VI"PRESS ENTER TO START ":99,VM,MN,SQ5000,SA1000,SV50000,DI0,GO,WA20  
MD101,RW538,IG20,MG"FOUND",MJ105,RL494,IG5000,MG"TOO FAR",MJ110,RP  
;  
MD105,ST,MG"POSITION = ":N,TP,MJ110  
;  
MD110,PM,MN,SA5000,SV500000,GH,WA50,SQ32767,WS100,MJ100
```

```
MD100,VI"PRESS ENTER TO START ":99,VM,MN,SQ5000,SA1000,SV50000,DI0,GO,WA20
```

This line waits for a carriage return to be entered via the RS232 port by using the variable input (VI) command. Then the unit enters velocity mode (VM), motor on (MN) and sets constants - force(SQ), acceleration(SA), velocity(SV). Direction 0 (DI0) commands the rod to move in a direction which increases the encoder count. WA20 allows any initial error to disappear before the program starts checking position error.

```
MD101,RW538,IG20,MG"FOUND",MJ105,RL494,IG5000,MG"TOO FAR",MJ110,RP
```

The position error is checked (RW538), if it is greater than 20 encoder counts, display message and jump to MD105. Else read actual position (RL494), if greater than 5000 counts, display message and jump to MD110

```
MD105,ST,MG"POSITION = ":N,TP,MJ110
```

Stop motion, display message (:N means no carriage return after message), Tell Position then jump to MD110.

```
MD110,PM,MN,SA5000,SV500000,GH,WA50,SQ32767,WS100,MJ100
```

Enter position mode, set acceleration and force higher. Issue go home (GH) command but wait 50ms before ramping force up to maximum. This is needed because if the force is increased immediately then any position error will be taken up, possibly deforming the measured component. Wait after stop 100ms then jump back to MD100.

Notes: If the actuator is in vertical orientation it will not be possible to land with a force less than the moving mass of the actuator with the above code. This is because when the controller sees a position error it will ramp up to the maximum allowable force in order to overcome that error (SQ5000 in this case). To overcome this situation, it would be desirable to limit the maximum force to a lower value (SQ500 for example) however it would not then be possible to control the motion of the actuator, the rod would just drop under its own weight.

It is possible to assign values to the minimum and maximum forces used, allowing the motion of the rod to be controlled, but limiting the maximum force that will be applied. The addresses to be used are Word 582 (minimum SQ value e.g. -30000) and Word 534

(maximum SQ value e.g. 0). It is necessary to write values to these words from the accumulator using the WW instruction, these commands replace the SQ command.

To put these values into the softland routine, the code would be as follows:

**MD100,VI"PRESS ENTER TO START ":99,VM,MN,AL-30000,WW582,AL0,WW534,SA1000,
SV50000,DI0,GO,WA20**

Note that these values would not work if the actuator was in horizontal because there is no force available to move the rod forward.

Position Error Checking

The position error checking routine is used to ensure the actuator has reached its target position and has not encountered an obstruction. If the unit has not reached position there will be a large position error present which will cause a large restoring force to be generated within the actuator which may exceed the 40% duty cycle. The checking routine consists of a subroutine of two lines which checks that the position error is within a certain range. This can be called at any time during the program.

The code is as follows: (Assume moves are defined on MD120, MD130)

```
MD120,PM,MN,MA2000,GO,WS100,MC245,MG“AT POSITION”,MJ130
;
MD130,GH,WS100,MC245,MG“AT HOME”,MJ120
;
MD245,RW538,IG20,MG“+ ERROR”,MJ246,IB-20,MG“- ERROR”,MJ246,RC
MD246,MF,EP
```

Note: PID tuning may influence settling time at position. Payload may cause steady state error at position. These factors should be taken into account when choosing the amount of error to check for, and the time after the move before the check is carried out.

Low Force at Home

If the unit is at rest and the rod is disturbed by an external force, either another part of the system or manually by an operator, this will also cause a position error to be present. To avoid any damage it is useful to reduce the holding force at this rest position, therefore bringing the actuator to within its 40% duty cycle.

The code is as follows:

```
MD120,PM,MN,MA2000,GO,WS100,MC245,MG“AT POSITION”,SQ10000,MJ130
;
MD130,GH,WS100,MC245,MG“AT HOME”,SQ10000,MJ120
;
MD245,RW538,IG20,MG“+ ERROR”,MJ246,IB-20,MG“- ERROR”,MJ246,RC
MD246,MF,EP
```

Vector interrupts

There are some points to note when using interrupts. The main point is that the interrupts are only sampled when the program is executing commands. It is therefore wise to avoid absolute delays in the program.

It is often the case that the unit is at a start position waiting for an input channel (from a PLC or push button for example) to start the program running. This could take the form of the following code

```
MD100,WN2  
MD101,PM,MN,SA1000,SV100000,SQ32767,MA3000,GO,WS100,GH,WS100,MJ100
```

The Wait On command would cause the program to stop executing until that condition is true. This means that the interrupts are not being sampled while the code is waiting for this condition. It would be better to use the If On command with the program in a loop which would allow checks to be made while at that position, also it would be advisable to add the other checks outlined in this section:

```
MD100,IN2,MJ101,NO,MC245,RP  
MD101,PM,MN,SA1000,SV100000,SQ32767,MA3000,GO,WS100,MC245,GH,WS100,MC245,  
SQ10000,MJ100  
;  
MD245,RW538,IG20,MG“+ ERROR”,MJ246,IB-20,MG“- ERROR”,MJ246,RC  
MD246,MF,EP
```

Input / Output Channels

Note: The method of operation of the input / output channels on the LAC-1 and LAC-25 are different. Please ensure that the correct instructions are followed for the controller that is being used.

LAC-1

This unit has 8 inputs and 8 outputs operating at 5 volt TTL levels. The connector on the controller is a 26-way high density d-type connector.

To activate an **input**, the appropriate pin on the connector (labelled input 1, input 2 etc.) must be connected to a common pin on the connector. This is a **volt-free contact**.

An **output** will be switched from **0 volts** between output pin and common when in the **off** state, to **5 volts** when **on**. If this has to be used to switch a 24V signal (on a PLC for example), a relay must be used. (e.g. RS 291-9675).

Refer to LAC-1 user manual for full specification on these signals.

LAC-25

This unit has 4 inputs and 4 outputs operating at between 5 and 24 volts. The connector on the controller is a 26-way high density d-type connector.

To activate an **input** signal a voltage must be applied to the input pin, with the input return connected to ground.

The **output** channels can be used to switch a voltage of between 5 and 24 volts dc. With the channel in the off state, no voltage will be passed. With the channel in the on state a voltage will be passed.

The commands used for these operations are as follows:

Outputs: **CN** = channel on e.g. **CN1** = **channel 1 on**
 CF = channel off e.g. **CF3** = **channel 3 off**

These commands will activate / de-activate an output to switch an external device.

Inputs: **WN** = Wait on e.g. **WN2** = **wait on channel 2**
 WF = Wait off e.g. **WF0** = **wait off channel 0**

These commands will cause an absolute wait in the program until the relevant channel becomes activated / deactivated.

IN = If On e.g. **IN0 = If on channel 0**
IF = If Off e.g. **IF6 = If on channel 6**

These commands will act as a normal 'if' command. If the condition is true, the two commands following the 'if' statement will be executed, otherwise they will be ignored.

DN = Do if On e.g. **DN5 = Do if channel 5 on**
DF = Do if Off e.g. **DF7 = Do if channel 7 off**

If the condition is true (on or off), the remainder of the command line after the 'do if' command will be executed, otherwise it will be ignored.

Wiring Diagram for Input / Output to PLC

LAC-1 to PLC – I/O channels are 5V TTL levels therefore to switch into 24V PLC system, a relay is required. Inputs to LAC-1 are volt free contacts. Output will switch 5V TTL relay.

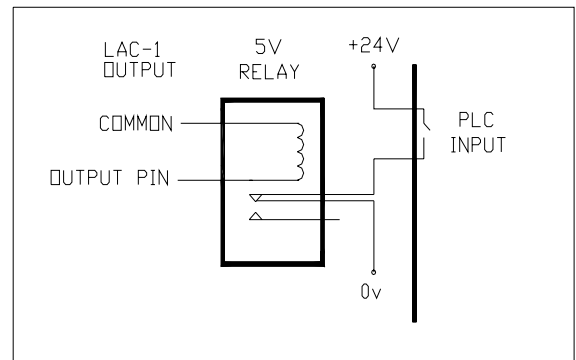
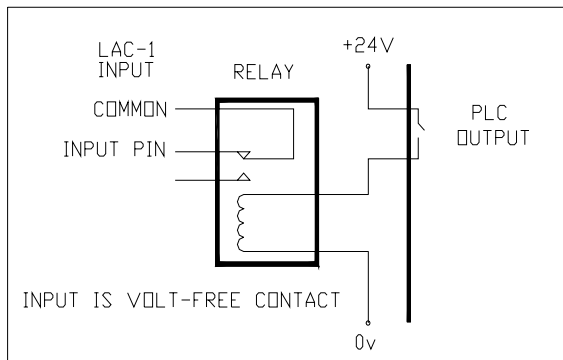

LAC-25 to PLC

Inputs and outputs are opto isolated 5-24V. They can be connected directly into 24V PLC inputs / outputs.

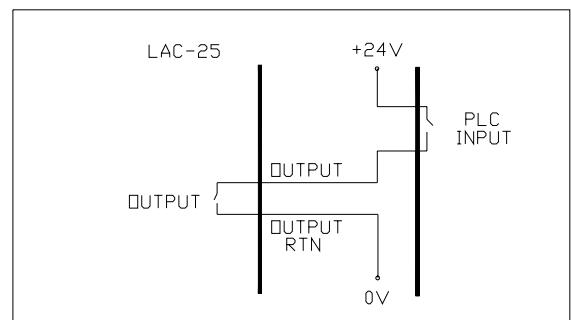
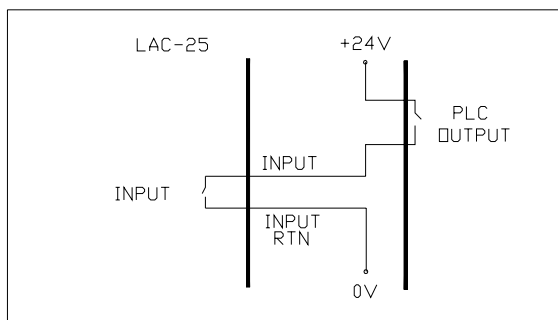

Data Capture

Overview

The LAC-1 and LAC-25 controllers have a facility for data capture. This allows certain system parameters to be read and stored at very accurate time intervals while motion commands are being executed. The data capture feature runs parallel to the main servo loop and does not affect the performance of the system in any way. The captured values can be saved to a file, or copied and pasted to a spreadsheet to verify performance of the system. This feature is very useful when tuning PID values and can also be used to check other conditions such as motion paths and servo output forces during a cycle.

Setting the system

The controller has three variables which must be defined in order to setup the data capture feature. These three addresses can be found on pages 42-44 of the LAC-1 manual, and pages 45-48 of the LAC-25 manual and are abbreviated in the table as follows:

Abbreviation	Description	Address	Function
RecRate	Data recorder sample rate	Word 422	Sets the time interval at which each data sample is taken. Load value of 1 for 200 μ s interval. Value 5 = (5*200 μ s) = 1ms interval. Value 50 = 10 ms interval Etc..
RecAddr	Data recorder sample address source	Word 424	Identifies the address of the variable to be captured (from the lookup table e.g. current position axis 1 = address 494)
RecSize	Data recorder sample address size	Word 426	Identifies if the variable to be captured is 32 bit , 16 bit or 8 bit. (from the lookup table - load value of 0 = 32 bit, value 1 = 8 bit, value 2 = 16 bit.

The captured numbers are stored in the same area of memory as the program macros. It is necessary to set aside a block of this memory where the captured numbers will be stored. This is done using the CS (Capture Storage) command. (e.g.CS300 will set up an area where

300 samples can be stored). This only needs to be defined once. If the RM (reset macros) command has been issued it will need to be defined again. Continual execution of the CS command will lead to an error #7 - 'Out of macro space'.

Data is captured in the program using the CD (capture data) command.

Data is retrieved from the controller using the DD (dump data) command.

Worked Example

Checking the profile of a linear move from 0 to 10mm. Position data is to be captured at 1ms time intervals, 300 samples are required. Actuator is LAL90, 5 micron resolution.

```
>
>
>mf,rm,cs300      Reset macros, setup storage for 300 data samples
>
>al5,ww422       Setup data capture rate of 1ms
>al494,ww424     Set address of axis 1 current real position
>al0,ww426       Set for 32-bit (long word) variable size
>
>
>fi,wi           Find index line of actuator (move rod by hand)
>
>sg100,si100,sd1200,fr1,ri1,il5000,sa1000,sv250000,sq25000    Set PID and velocity
values
>
>pm,mn,gh,ws200  Send actuator to home (index line) position
>
>
>pm,mn,ma2000,go,cd300,ws200  Move to 10mm (2000 count) position, capture 300
samples
>
>dd300           Dump data (lists 300 captured samples)
0
0               Copy and paste these numbers to excel spreadsheet
1
2
5
10
14
15
21
30
etc....

2000
2000
>
>
>
>
>
>
>
```

LAL90 move to posn 2000

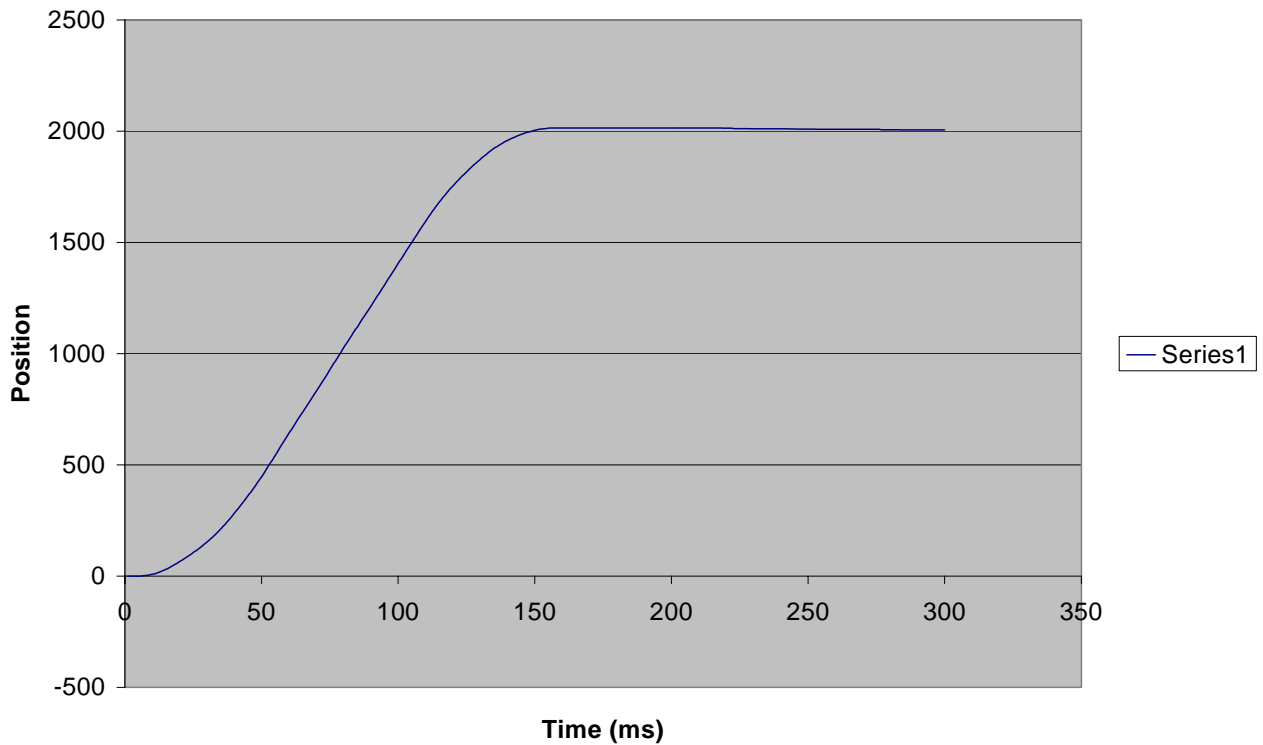

If this data is used to tune PID values, it can be seen from the graph there is a small amount of overshoot error at position. This can be eliminated by increasing the SI (set integral) or IL(integration limit) commands and running the profile again to verify.

Useful variables to be captured

Data to be captured	Address	How to program
Position axis 1	Longword 494	al494,ww424,al0,ww426
Position axis 2	Longword 638	al638,ww424,al0,ww426
Position error axis 1	Word 538	al538,ww424,al2,ww426
Position error axis 2	Word 682	al682,ww424,al2,ww426
Servo output axis 1	Word 530	al530,ww424,al2,ww426
Servo output axis 2	Word 674	al674,ww424,al2,ww426

Quality Control / Gauging Applications

Several features of the SMAC voice coil actuators and servo controllers make the systems suitable for a range of gauging and quality control applications:

1. **Force control** – This enables the system to apply a very soft force to a surface, enabling measurement of fragile parts and detection of soft, compliant surfaces.
2. **Velocity control** – Enables the unit to minimize impact force onto a surface.
3. **Position feedback** – Allows the user to monitor position at all times.
4. **Force feedback** – Allows the user to monitor force (current) at all times.
5. **Self-teach** – The unit can ‘learn’ a target position.
6. **Mathematical functions** – the controller can perform comparisons of actual measured values to user-defined tolerance ‘windows’.
7. **Digital I/O** – Used to signal pass / fail situation. Can also be used to identify too high / too low values, feeding back to a host PLC or PC to adjust the manufacturing process accordingly.
8. **RS232 Communication** – This can be used to send ‘real values’ to a host PC for data collection or Statistical Process Control

The usual sequence for measuring a surface and checking a position tolerance is as follows:

1. Wait for start signal, Rapid approach close to surface.
2. Enter velocity mode, set low force, low velocity values, move towards surface.
3. Check position error, if allowable value is exceeded jump to step 4, else repeat.
4. Read position (**RL494**), check if greater (**IG**) than or if below (**IB**) stored values.
5. Signal pass/fail or too high/too low, retract to start position
6. Repeat.

To check a force value (e.g. switch test), as above except:

4. Depress switch to test position, read force value, check if greater than (**IG**) or below (**IB**) stored values.

Sample code for checking position (add to softland routine in Actuator User Manual)

e.g. Upper position limit = 2000 encoder counts, lower position limit = 1000 encoder counts
Output channel 2 on (CN2) = too high, Output channel 3 on (CN3) = too low, output channel 0 on (CN0) = good

RL494 = read axis 1 (linear) position

The If commands (IG,IB,) allow the program to continue executing if the condition is true, otherwise the two commands following the If command will be ignored.

**MD107,RL494,IG2000,MG"TOO HIGH",MJ108,IB1000,MG"TOO LOW",MJ109,
MG"POSITION OK",CN0,MJ110**

MD108,CN2,MJ110

MD109,CN3,MJ110

MD110,.....next part of program etc..

Sample code for checking force (add to softland routine in Actuator User Manual)

e.g. Upper force limit = SQ20000, lower force limit = SQ18000

Output channel 2 = force too high, Output channel 3 = force too low, output channel 0 = force value good

MD106,PM,MN,MA5000,GO,WS200 (move to force test position)

**MD107,RW530,IG20000,MG"TOO HIGH",MJ108,IB18000,MG"TOO LOW",MJ109,
MG"FORCE OK",CN0,MJ110**

MD108,CN2,MJ110

MD109,CN3,MJ110

MD110,.....next part of program etc..

Worked example (LAL37 actuator, 5 micron encoder)

Softland on surface, read position, check if within tolerance, retract

```
>mf,rm          Reset macros
>
>
>fi,wi          Find index line of actuator (move rod by hand)
>
>sg100,si100,sd1200,fr1,ri1,il5000,sa1000,sv250000,sq25000    Set PID and velocity
values
>
>pm,mn,gh,ws200  Send actuator to home (index line) position
>
>
>          Define softland routine (as per Actuator User Manual)
>
>MD100,VP"PRESS ENTER TO START ":99,VM,MN,SQ5000,SA1000,SV50000,DI0,GO,WA20
>;
>MD101,RW538,IG20,MG"LANDED AT ":n,MJ105,RL494,IG9000,MG"PRODUCT MISSI
NG",MJ110,RP
>;
>MD105,ST,MG"POSITION = ":N,TP,MJ107
>;
>MD107,RL494,IG2000,MG"TOO HIGH",MJ108,IB1000,MG"TOO LOW",MJ109,MG"POS
ITION OK", CN0,MJ110
>;
>MD108,CN2,MJ110
>;
>MD109,CN3,MJ110
>;
>MD110,PM,MN,SA5000,SV500000,GH,WA50,SQ32767,WS100,MG,MJ100
>
>
>MS100
PRESS ENTER TO START
LANDED AT POSITION = 1317
POSITION OK

PRESS ENTER TO START
LANDED AT POSITION = 684
TOO LOW

PRESS ENTER TO START
LANDED AT POSITION = 2428
TOO HIGH

PRESS ENTER TO START
etc.....
```

