



MR MRH

# Motion Control Rotary Stages

Optical Tables

Stages

Optical Mounts

Components

Motion Systems

Education Systems

Lasers

Optics & Crystals

Other Equipment

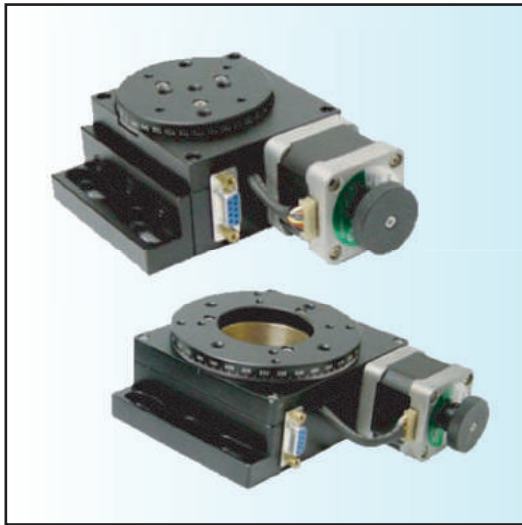

## Specifications

- Drive Type: Stepping Motor
- Weight : 1.1 ~ 3.2 kg
- Loading : 10 ~ 50 kg
- Resolution : 0.0025° / 0.00125°
- Repeatability : ±0.0025° / ±0.00125°
- Surface Parallelism: ±0.0025° / ±0.00125°
- High accuracy and loading
- Customized specifications upon request
- Metric / Imperial Version available
- To order Imperial model please add \*-I\* to item

## Specification & Item Numbers

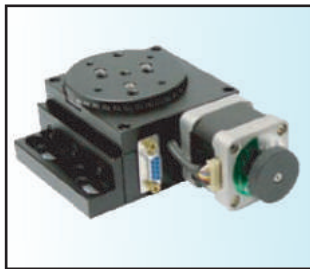

MR-66

MR- 66

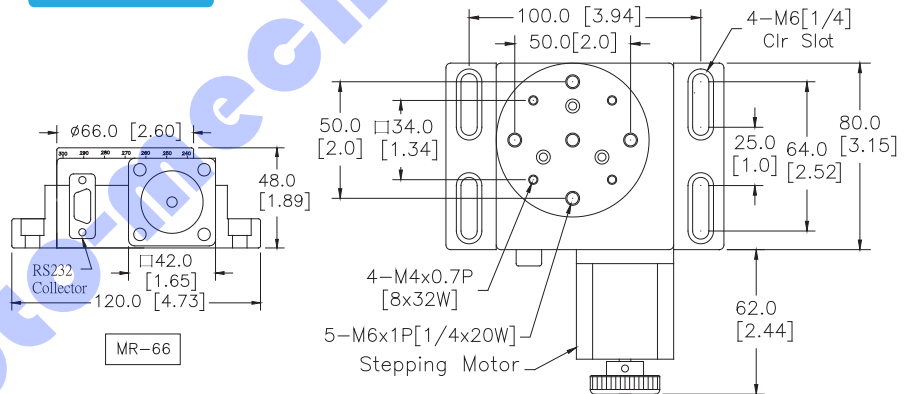

MRH-46

MRH- 46

